



Designed & Engineered in California



Ridiculously Easy CNC

Single Operator / 1-day training
No G-code needed / No backbreaking work

WWW.CNCFACTORY.COM

Spring 2022





Leave the Hard and Dirty Work to Us

So you've done some reading, talked to friends, consulted your astrologist and are now ready to automate with CNCs. Or maybe you've been using manual machines or older generation CNCs and are now ready for an upgrade. Whatever the case, we are here for one purpose: to make your life a whole lot easier.

Not all CNCs are created equal and our 5th Generation machines are designed to automate your production from the tiniest tasks (no more daily homing!) to the most backbreaking and mentally-tasking ones. Imagine all the things you have to go through to produce a single product today. All those can now be replaced by just pressing a few buttons *without* the need to learn any code. 5G CNC is also fully customizable—just tell us what you need and we'll customize our base models for you.

As a cabinetmaker for over 25 years, I have longed to make CNC automation as commonplace as a table saw for my fellow woodworkers. Now, high-end features at an accessible price is here.

Easy to buy, easy to use, and easy to maintain. That's the CNC Factory's promise.

Chris Corrales



HAPPY WITH CNC FACTORY?

 (714) 581-5999

Write a Review



Scan to see 4 ways to give feedback online. We'd love to hear from you!

Refer to a friend

Get a **referral fee** or a bigger **tool credit** for every machine purchase your referral makes. Contact anyone from sales if you know someone looking for CNCs and we'll take care of the rest.

 FOR MACHINE QUOTES & INQUIRIES
sales@cncfactory.com

FOR TECH & CUSTOMER SUPPORT
support@cncfactory.com

FOR FINANCING
easypay@cncfactory.com

FOR MARKETING
marketing@cncfactory.com

EASY AS CNC

Watch how Loren operates our 5th Generation machines for the very first time. If it looks ridiculously easy, it's because it **is**.

ridiculously easy
TOOL MEASUREMENT

Automate tedious tasks with a press of a button.



Scan for demo video
or go to:
<http://bit.ly/tool-measure>



ridiculously easy
DRIVERLESS OPERATIONS

Load, align, mark, cut, unload & clean in autopilot.

Scan for demo video
or go to:
<http://bit.ly/driverless-cnc>

ridiculously easy
PLUG & PLAY EXPANSION

Grow your machine at your own pace.



Scan for demo video
or go to:
<http://bit.ly/plugandplay-cnc>

5G CNC ROUTERS

Designed & Engineered in California, our 5th Generation CNC routers are made from the best technologies from around the world: Italian spindles, German wiring & rail systems, Syntec controllers, and Japanese servo motors among others. All parts are 100% stocked in the USA so you'll get them when you need them.

✓ **Single or No operator**

✓ **Auto pilot mode**

✓ **No G-code experience needed**

✓ **Touch screen vacuum controls**

✓ **Auto tool measuring**

✓ **No daily calibration**

Old CNC machines use position sensors to find its starting point or its "home". This burdens the operator with the time-intensive task of recalibrating the machine every time it's turned on or reset. Lost power in the middle of the operation? Old machines would have you start all over again. 5G CNC saves you from this chore.

✓ **At screen cabinet library**

✓ **Expandable**

Applications:



Wood



Plastics



Acrylic



Light Metals

Table Sizes:

4'x8'
4'x10'
5'x10'
5'x12'
6'x12'
Custom

Inclusions:

- Lifetime technical support (email and phone)
- CNC University training (Santa Ana, CA)
- User manual & access to Online Knowledge Center
- Spoilboard
- Clamps for hoses (for vacuum & dust extraction)
- Tool holders
- ISO-32 & metric allen wrench set
- HD webcam, mouse & keyboard

Software

: Compatible with any CAD/CAM software that exports G-code. VCarve Pro & KCD can be pre-installed if you qualify.

Power

: 3-phase by default. Single phase available as an upgrade.

Customizations

: Table sizes, gantry heights + other custom requirements are available.

5G CNC CONTROLLER

Safety Lights
alert of any error

WiFi, Ethernet & USB Connectivity

Mobile with Tiny Footprint
about 2.7 sq.ft.



HD Webcam
For virtual technical support & remote access

21" Touchscreen with PC front-end

- The biggest screen of any CNC router in the market.
- Lets you design at the machine with at screen cabinet & design software.



SCAN FOR VIDEO

Wireless Controller

5G CNC EXPANDABILITY

5G CNC lets you upgrade your machine anytime! True expandability is not just a matter of adding; most routers allow you to retrofit new parts in but they can come at a cost and void your warranty. All our routers are pre-wired for expansion:

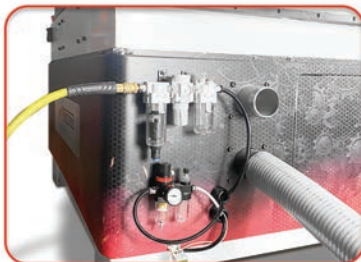

2nd Vacuum Pump Port

Whenever you need additional workholding, just press a button to activate.



Plug & Play Ports (For XPR Series)

To connect light curtains, loading & unloading tables, and other future upgrades.

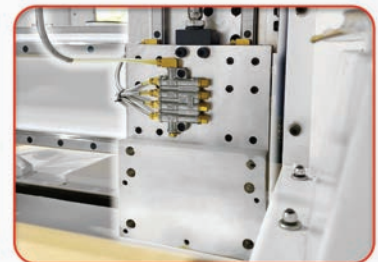

Machine Head Expansion Panel

To connect drill blocks, marking blocks, laser engravers, or horizontal & angled drills.

NEED A DEMO?

 (714) 581-5999

 sales@cncfactory.com

In-person

Schedule a visit at our Santa Ana, California showroom. Also inquire about visiting any of our satisfied customers' shops near you.

Virtual

Send us a design/specific cut you'd want to see and we'll cut live via Facetime/Zoom or shoot a custom demo video for you.

5G CNC ROUTERS

BEST FOR SMALL SPACES

VIPER XP



Scan to view in 360° 3D
or go to:
<http://bit.ly/viper-360>



STARTS AT:

\$37,900

DIRECT FACTORY
PRICING

AS LOW AS
\$602.60/mo*

*With CNC Factory Easy Pay Financing.
36-month term after 50% down
payment. Rates will change depending
on term and initial payment.

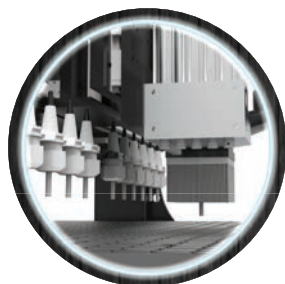

Change tools quickly. Load on all 4 sides.

Automatic tool changer is mounted on the gantry for an unobstructed work area and fast tool changing.

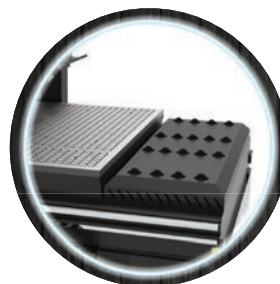

Easy Alignment with loading wheels & material position pins.

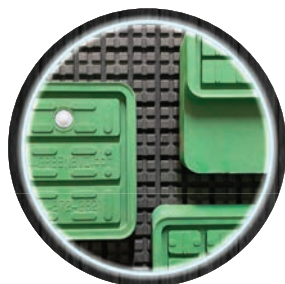

Aggressive Material Hold Down

Pod-ready, high-flow phenolic vacuum table works with 1 or 2 vacuum pumps.



Control Vacuum Automatically via the touchscreen. No more manual cranking of vacuum valves!

Tiny Footprint for Smaller Shops

These are the dimensions for the 4'x8' model.
Weight: 5,700lbs.

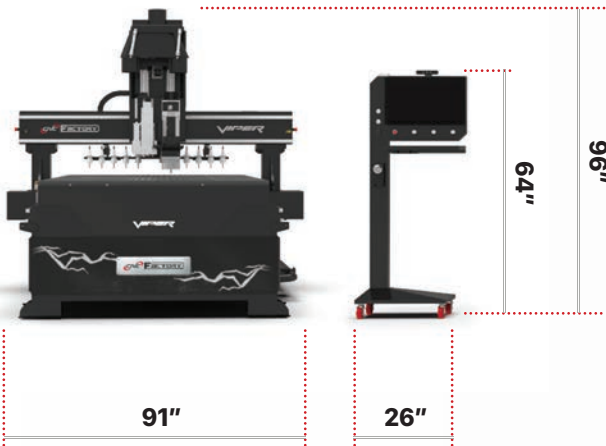
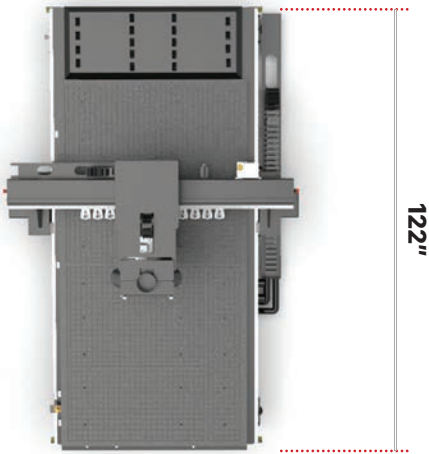

Measure Tools Automatically

Measure tools precisely in under a minute with a press of a button.

SPECS AT A GLANCE:

Spindle:

- 10HP air-cooled ATC spindle w/ 8 second tool changes
- 1000 IPM cutting speed
- 2000 IPM travel speed

Rail system:

Helical rack & pinion rail system for X & Y axes

Automatic tool changer on gantry:

8 tools

No operator mode:



Auto pilot mode:



No homing or alignment servo system:



Onboard air-conditioning & cooling:



Pressurized automatic oil lubrication:



Anytime upgrades:

- 12HP spindle
- 12-tool ATC
- 9-position drill block
- 4-port marking block
- V300 vacuum pump
- Mister kit
- Vision marking tools
- Laser module

WHAT USERS HAVE TO SAY:

"Easy to use, small footprint, profitable, and great support at a price point that works for me!"



Aldo Pereira
Master Carpentry
Myrtle Beach, SC

5G CNC ROUTERS

BEST IN EXPANDABILITY SIDEWINDER XPR



Scan to view in 360° 3D
or go to:
<http://bit.ly/sidewinder-360>



STARTS AT:

\$46,900

DIRECT FACTORY
PRICING

AS LOW AS
\$745.70/mo*

*With CNC Factory Easy Pay Financing.
36-month term after 50% down
payment. Rates will change depending
on term and initial payment.

Grow your Machine as your Business Grows

External plug & play ports let you upgrade your machine whenever you are ready, just plug them in! No additional wiring/retrofitting costs needed!

Unloading Table
anytime upgrade

Drill Block
anytime upgrade

Robotic Loading Arms
anytime upgrade

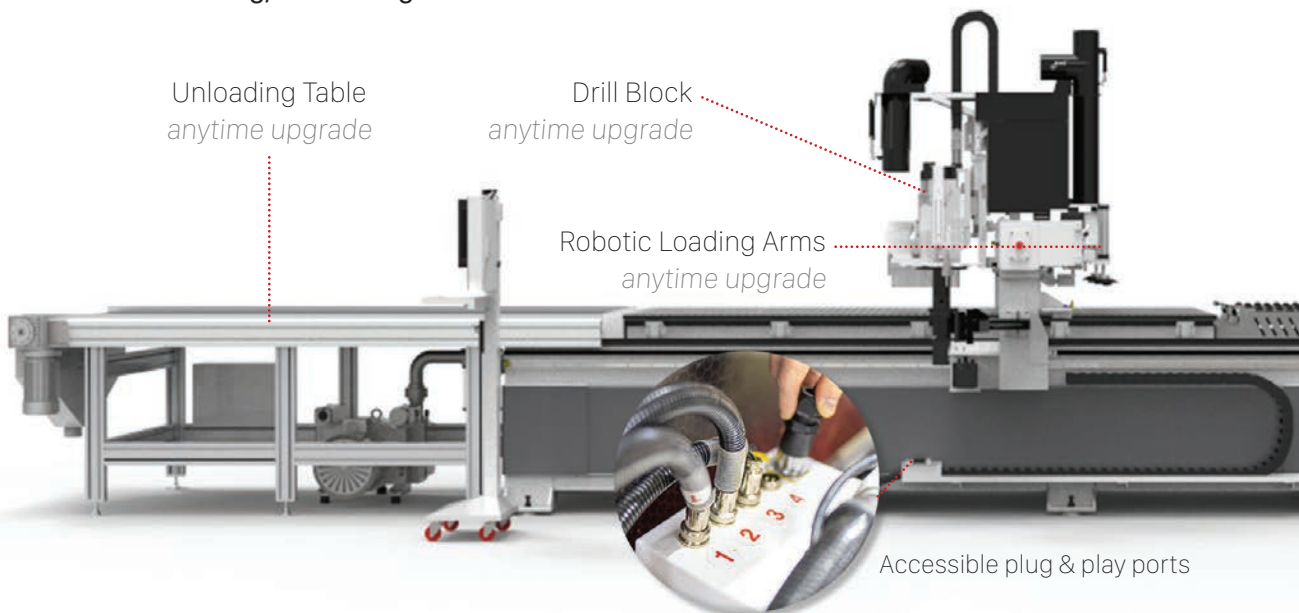

Accessible plug & play ports



Align & Clean Material Automatically

Robotic unloading cleans the spoilboard in under 30 seconds. Rear & side pushers upgrade also aligns your material to pop-up pins and guide rails.

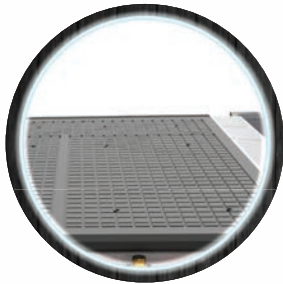

Intelligent Material Hold Down

The dual-layer, high-flow phenolic vacuum table has over 80 vacuum access points for aggressive material hold down. Control these zones + up to 2 vacuum pumps easily via the controller's touch screen.

Loading Table
anytime upgrade

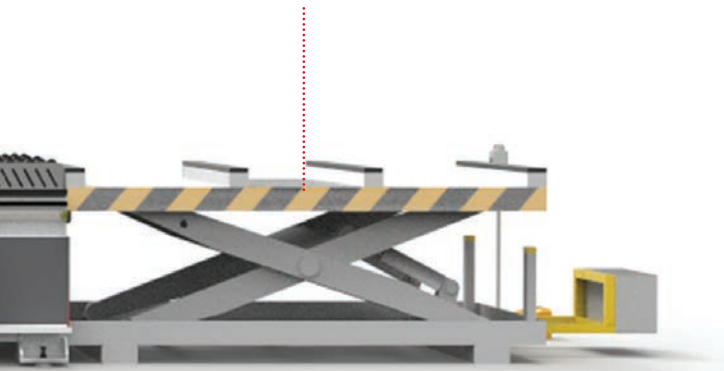

SPECS AT A GLANCE:

Spindle:

- 12HP air-cooled ATC spindle w/ 8 second tool changes
- 1200 IPM cutting speed
- 2200 IPM travel speed

Rail system:

Helical rack & pinion rail system for X & Y axes

Automatic tool changer on carousel:

8 tools

No operator mode:



Auto pilot mode:



No homing or alignment servo system:



Onboard air-conditioning & cooling:



Pressurized automatic oil lubrication:



Anytime upgrades:

- 12-tool ATC
- Hydraulic loading table
- Unloading conveyor with material sensing
- Robotic loading arm & material alignment
- Robotic material sensing dust hood
- 9-position drill block
- 4-port marking block
- V300 vacuum pump
- Mister kit
- Vision marking tools
- Laser module

WHAT USERS HAVE TO SAY:

"We have little to no issue with the Sidewinder. If anything pops up— a quick phone call and it is resolved!"



Steve Rouse
DMR Woodworks
Pensacola, FL

5G CNC ROUTERS

BEST FOR DRIVERLESS OPERATIONS

PYTHON XPR



Scan to view in 360° 3D
or go to:
<http://bit.ly/python-360>

FDMC
EDITOR'S CHOICE
Best CNC



STARTS AT:

\$79,800

DIRECT FACTORY
PRICING
WITH LOADING &
UNLOADING TABLES

AS LOW AS
\$1,268.81/mo*

*With CNC Factory Easy Pay Financing.
36-month term after 50% down
payment. Rates will change depending
on term and initial payment.



No Backbreaking Work or Experience Needed

Load, align, cut, clean, and unload material with a press of a few buttons. No special skills or heavy lifting needed.

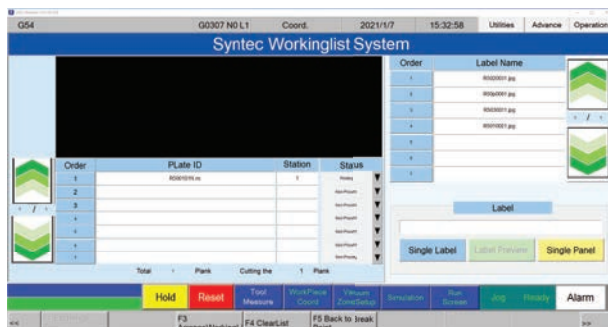

Work in Autopilot Mode

Working lists lets you queue hundreds of jobs, one after the other. Your work progress is easily monitorable so there's continuous production even if your operators change shifts. Manager access and troubleshooting can also be done remotely.



Maintain a Clean Workspace

Its patent-pending, material-sensing dust hood knows the thickness of the material and the corresponding height of its required tool. This “sensing” lets the hood hover at the perfect spot over your material— creating a seal to prevent dust from escaping without bending the dust brush, whether you are switching from thin to thick materials, or are using shorter or longer tools.

SCAN FOR VIDEO



Label Parts Automatically

Label parts with production info via the patent-pending, onboard robotic label printer & robotic upgrade. No manual application & human errors. No stop signs.



Unparalleled Support

Every Python comes with 1 year of on-site support for issues that cannot be solved remotely. Get peace of mind knowing that we always got your back.

SPECS AT A GLANCE:

Spindle:

- 12HP **HSD** air-cooled ATC spindle
- 1500 IPM cutting speed
- 2500 IPM rapid travel speed

Rail system:

Helical rack & pinion rail system for X & Y axes

Automatic tool changer on carousel:

12 tools

No operator mode:



Auto pilot mode:



No homing or alignment servo system:



Onboard air-conditioning & cooling:



Pressurized automatic oil lubrication:



Anytime upgrades:

- 9-position drill block
- 4-port marking block
- V300 vacuum pump
- Mister kit
- Vision marking tool
- Robotic arm to handle post production

WHAT USERS HAVE TO SAY:

“...when taking into account the Python’s impact on downstream processes, most notably assembly, they helped increase the plant’s overall productivity by 10%. That’s equivalent to six full-time employees! The machines paid for themselves within 18 months.”



Bill Brugmann
School Specialty
Lancaster, PA

FAQs

• Can I get financing?

We make buying easy with 2 financing options so you don't have to spend all your hard-earned money in one go. You can start by submitting an application form. Download it at cncfactory.com/financing or scan here →



	CNC FACTORY'S EASY PAY	HARBOR CAPITAL FINANCING
PRE-REQUISITES	In business for at least 1 year	None
CREDIT CHECK	None	Yes
DOWN PAYMENT	50%	As low as 0%
PERCENT FINANCED	Up to 50% Max of \$200,000	Up to 100% including soft costs Max of \$ 500,000
INTEREST RATE	9%	Fixed rates. Contact for latest APR.
TERMS	Up to 36 months	Up to 84 months
EARLY PAYOFF	With discount	No penalty
APPROVAL	1 day	1 day

• What if I need parts?

You can order via www.cncfactorystore.com or call us at (714) 581-5999. All major components (wearable parts excluded) have an 18-month warranty. Everything needed to service your CNC Factory machine is 100% stocked in California.

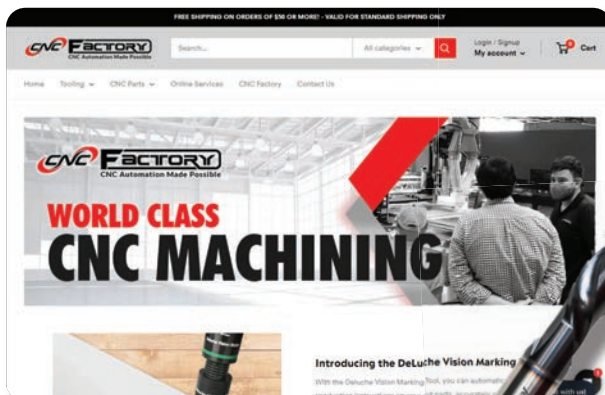

DeLuChe Tools sold here have a lifetime guarantee where you can get a new replacement tool, anytime, for whatever reason, up to a 50% discounted price. By getting a new tool whenever your old one wears down, you save the effort of resharpening bits and computing for tool compensation.

“ Save thousands + no more compensation for resharpened bits! ”

- **Do I need CNC experience?**

Absolutely not! 5th generation CNC machines are designed for ease of use so you can do more with less, even if you don't know any G-code. And if you have an existing CNC machine or some experience, the learning curve will even be shorter.

Our intuitive graphical interface, along with the automation of the simplest tasks (such as daily calibration) to more error-prone tasks (such as applying labels or marking the edgeband location), all contribute to the need for fewer employees with less experience.

- **Is installing or learning the machine easy?**

When you purchase a machine, you'll undergo an onboarding process that will give you a step-by-step guide on what to expect and prepare for installation. You'll mostly just need to level your machine, and plug in power, air, and dust extraction. Once turned on, your CNC machine will already know where it is with no calibration needed. Sometimes, other parts would need to be installed that were removed for easier transport (such as a dust shroud, ATC carousel), but most are plug & play.

Learning is just as easy as setting up. You can learn how to use the machine in just a day, either virtually or in person. For troubleshooting, we can even control your machine remotely and see it work in real time with our built-in HD camera. We also have easy-to-follow videos in our Online Knowledge Center and a CNC Factory University in California as additional resources.

- **Which software should I use?**

There are a lot of exciting choices and new software that will cater to your business— from cabinetry, engraving, to plastics and signs. Since our controller has a PC front-end, our CNC machines are virtually compatible with every software and CAD/CAM on the market. With 5G CNC you can have your favorite software library directly on your CNC screen. Simply point and click on your screen to make your design and cut. No more hired programmers.

- **What type of support can I get?**

Lifetime! And it's free! All of our CNC machines come with lifetime machine support (excluding installation and training) via phone, email, and virtual platforms. It is also backed by the longest 18-month CNC warranty in the industry. Soon, our new CNC Cyber Operation Center can even run your production for you.



COMING UP

CNC Factory's Chris Corrales has been selected to present 2 learning sessions at the 2022 IWF Education Conference:

Aug 23, 9AM: Profit-focused lean manufacturing with CNC machines

Aug 24, 10:30AM: CNC machines for the modern cabinet shop

Sign up at www.iwfatlanta.com/education/

Want FREE expo admission? Check out www.cncfactory.com/iwf/



EDGE BANDERS BADGER SERIES



Pre-Mill



Glue



Strip Feed

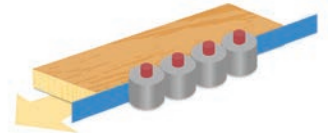

Pressure Rollers



End Trim

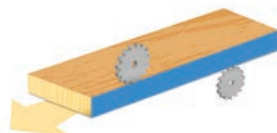

Super Finish



Flat Scrape



Buffing

Model &
Starting Price

Scan QR Code
for 360° 3D

BADGER 3600
\$23,900



Top & bottom trimming,
cutting, rough & fine scraping,
liquid cleaning & buffing

+
Corner-rounding
station

+
PUR zero
glue line station



BADGER 4600
\$34,900



BADGER 5600
\$59,900



STANDARD BADGER FEATURES:



Independent Motor Controls

Independent high frequency motors for each operation gives you the freedom to set your desired level of automation and makes it easier to service.



Flexible With Materials

Works with veneer, tapes, PVC or solid wood up to 3mm thickness.



PLC Touch Screen Interface

User-friendly, no thinking controls at your fingertips. With workload history access.

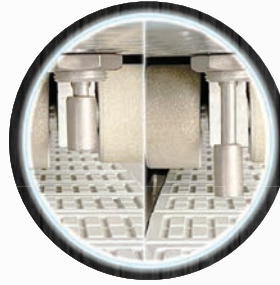

Built-in Material Stop

Automatically closes and opens so you don't have to guess the correct placement timing for your next piece of material.

BADGER UPGRADES:



Pre-Mill Station

Sometimes, when cutting pieces for edgebanding, the thickness of the edgebanding tape is not calculated and this creates gaps during installation. The Pre-mill station tapers off a layer of the material that is equal to the thickness of the edge banding tape. As a result, your final edge banded material will have the same size as the original material you fed into the machine. The pre-mill also cleans up rough edges if you cut your parts with a table saw, plus warms it up for better glue adhesion.



Return Conveyor

The Badger is designed to easily connect to CNC Factory's return conveyor system, which brings back edge banded material as long as 100" back to the operator for non-stop edgebanding. Double your production with only 1 operator that stays in the production spot.

CNC FASTENER INSERTION

SCORPION LDR



STARTS AT:

\$79,800

DIRECT FACTORY
PRICING

With 10X stronger H-clip insertion, our Scorpions are boring & hidden fastener/dowel insertion powerhouses that reduce your assembly time by 70%. With 1-4 independent workstations and a graphical touchscreen interface, it only needs a single, unskilled operator.

It is compatible with fasteners such as:

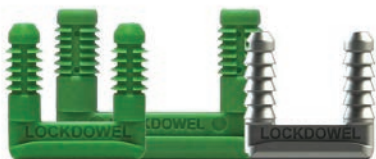

LOCKDOWEL



OVVO



FASTENLINK

Need something smaller?

SCORPION X

Same Scorpion power. More Compact.

- 1-2 workstations
- 48" material working space

STARTS AT:

\$49,800



5G CNC FEATURES:

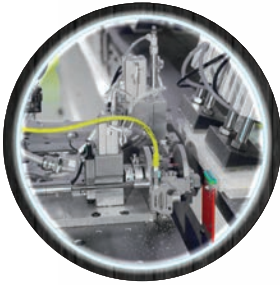

Fastest Drilling on the Market

The patented high-speed dual drilling system bores 2 holes at a time to reduce processing by more than 50%. No manual changing of bits as it automatically selects from the drill library.



Patent-pending Automatic Jam Cleaning

In rare cases of clip jamming, it self cleans, reloads, and resumes operation on the same position. No more wasted pieces.



Robotic Lean Manufacturing

It can be manned by a single, unskilled operator and allows rapid assembly & flat packing.



Multiple Operation Modes

Only the Scorpion offers graphical Parametric, G-code, Manual Editor, and Multi-edge modes. Easily integrates with popular CNC software.

SCORPION LDR SPECS AT A GLANCE:

- CNC edge boring
- Automatic wood dowel; plastic barbed channel lock, H-clip, E-clip, and spring pin insertion
- Patented dual high-speed drilling
- On-board air-cooled spindle with auto sensing & positioning
- 2 robotic insertion guns & upgradable to 5 guns
- Drill Library including 5mm, 8mm and 8.2mm
- 96" material working space
- High capacity adjustable material hold down
- Auto jam self-cleaning
- Works with standard dowel clips with no tool changing
- Touch screen interface
- With 5G virtual remote access
- 5G CNC helical rack & pinion rail system
- Wireless barcode reader
- CNC remote control

Scan to view demo video
or go to:
<http://bit.ly/scorpion-cnc>



THERMOFOIL PRESS

CYCLONE 4896

\$29,900

DIRECT FACTORY PRICING

Press virtually any 3D shape using PVC sheets, rigid sheets, PS sheets, acrylic, ABS and wood veneers. Ridiculously easy to use, a single operator can produce over 300 pieces per 8-hour shift. Get short-cycle, high-yield pressing with new generation technology.



Easy to Use

Straightforward PLC-controlled automated heating, vacuum forming & cooling— all with a press of a button.



Easy to Maintain

With independent, interchangeable heating elements that are easy to replace.

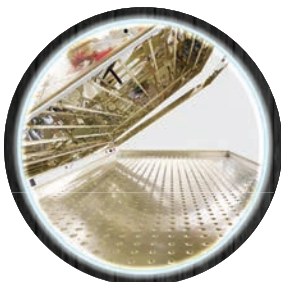

Full Process Area Access

Designed so nothing gets in the way of pressing. The heating lamps are also arranged to avoid cool spots that are common on lesser-engineered presses.



Tiny Footprint

Has the smallest footprint and can be outfitted with caster wheels to make it mobile.

RECOMMENDED ADD-ON

V300 VACUUM PUMP

\$6,900

DIRECT FACTORY PRICING

Quiet at 80 decibels, the V300 vacuum pump is energy-saving and has constant vacuum hold down communication with our routers. All CNC Factory routers are pre-wired for up to two V300 vacuum pumps.

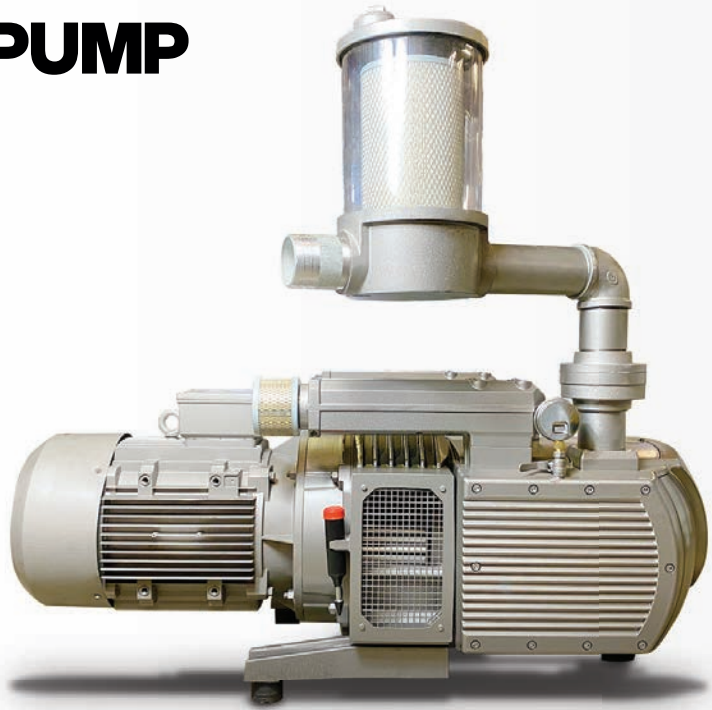

Easy to Use

Paired with our 5G CNC routers, there is no need to turn the vacuum on/off repeatedly when removing cut parts. Turn up to 2 pumps on/off from the controller with a press of a button.

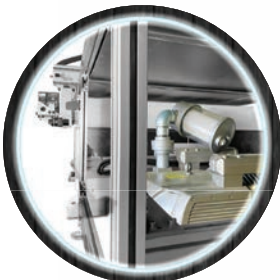

Production Workhorse

Dependable in keeping optimal work holding for any CNC machine. Its thermal and electric phase protections protect the motor from burning out due to any heat/power issues.



Easy Maintenance

Just monthly cleaning of the filter, air ducts, and lubrication every 200 hours of use. Vanes may be replaced if needed.

COMING THIS 2022

CNC CYBER OPS



We'll run your machines for you

virtually from the CNC Factory Cyber Operations Center.

Just pay for a flat monthly fee. Cancel anytime.



In-house operator



Non-stop production

WWW.CNCFACTORY.COM/CYBER-OPS