



PYTHON XPR

DRIVERLESS • FULLY-LOADED • BATTLEWORTHY



The pinnacle of 5th Generation CNC technology, it is completely driverless and can let your operations go into autopilot by pressing a few buttons. From loading to spoilboard cleaning to rapid cutting to parts marking and unloading, the Python takes away all the heavy lifting and critical thinking required of a skilled operator.

QUICK LINKS



See the PYTHON XPR in action on Youtube

[SEE THE PYTHON IN 360°](#)

[SEE FINANCING OPTIONS](#)

[BUILD YOUR OWN](#)

PYTHON AT A GLANCE

STARTS AT \$76,800

DIRECT FACTORY PRICING

Inclusions:

- Lifetime Technical Support
- CNC University Certification

Features:

- 12HP ATC **HSD** air-cooled spindle
- No machine homing or alignment
- Driverless mobile control center with 21" touch screen and wireless remote
- 12-tool rotary with rapid 8-second tool change
- Robotic cleaning & unloading
- Zoned dual-layer, high-flow vacuum table
- Robotic material alignment ready
- Fast cutting speeds - up to 1000 IPM & 2500 IPM rapid travel
- Auto tool length, pressurized lubrication & robotic material sensing dust hood
- Robotic cleaning, laser-guided loading & unloading
- 5th Generation Helical Rack & Pinion
- Plug & play add-ons

Built-in Software Option:

KCD
software

ABOUT US

CNC Factory, Inc., located in Southern California, USA, began over 20 years ago as a one-man business with a clear goal and dedication to helping companies embrace CNC automation.

This vision is core to our legacy as we design and manufacture high-quality, precision CNC routers and machining centers, to meet the urgent business needs of our customers. At CNC Factory, we understand since inception, that providing the fastest, most accurate and dependable CNC Machines and supporting products is only the beginning of meeting our customers' needs— we never leave them all by themselves. Together with our German, Italian and worldwide support partners, world-class machining capability is truly just the beginning.

With us at the back of (sometimes beside) our customers, their businesses have grown and we've meet their needs from quality and efficiency to the bottom line. We think beyond machine building. We also grant access to factory direct support and training before and after installation for our customers.

THE MOST IMPRESSIVE SERVICE AND
SUPPORT WARRANTY IN THE USA



Lifetime Support
included with every
Python Machine Center



**Advance Exchange
Program** on major
components



18-Month Warranty for greater
peace of mind



On-Site Support
options available



Virtual Support to help guide
your staff at the machine level



On-Site Installation and
training options available

WEST COAST
California

EAST COAST
New Jersey

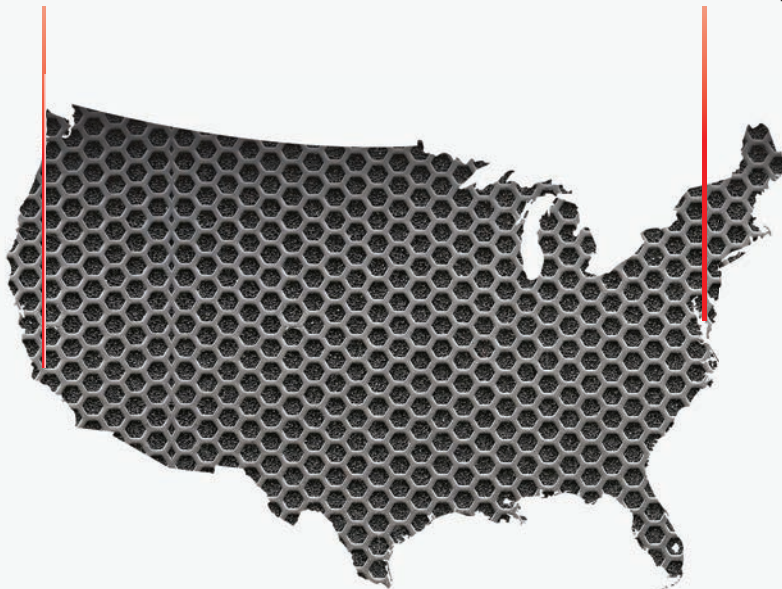

www.CNCfactory.com



714-581-5999



sales@cncfactory.com

5 G CNC FEATURES



ROBOTIC LOADING & MATERIAL ALIGNMENT

Robotic material loading that saves you from back-breaking work. Load the table with 30-40 sheets at a time and use a foot switch to operate. Works in manual and automatic modes and has an integrated height sensor that automatically raises the material after the last one has been picked up by the loading suction arm.

Your material is then aligned against alignment pins via rear and side pushers. These pins automatically retract before running a program. The Python is designed to be loaded from all four sides, and has rear-integrated material moving wheels.



ROBOTIC CLEANING AND UNLOADING

The days of stopping the CNC to mark parts, unload, and manually clean the spoilboard are a thing of the past. The Python XPR performs this robotic unloading and spoilboard cleaning in 30 seconds with no human intervention.

The unloading conveyor also unloads processed material to match the pace of your operator. Its material sensing automatically stops the conveyor when the material reaches its edge—a perfect spot for the operator to pick your part up.

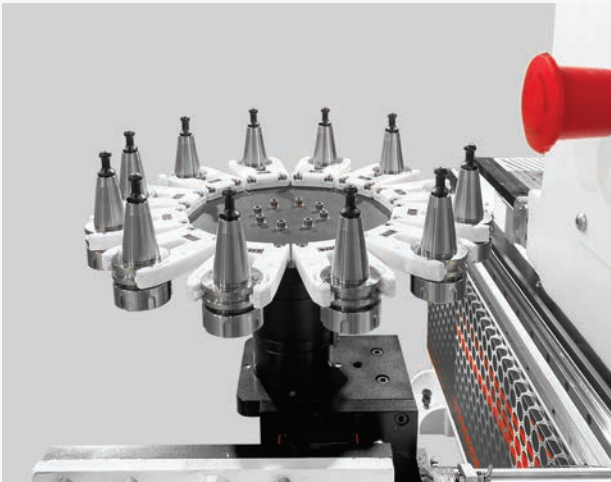

12-TOOL SERVO ATC

Servo-controlled rotary ATC 12-tool carousel performs tool changes under 8 seconds. Mounted on the gantry for at-the-location tool changes compliments the rapid travel of 2500 inches per minute; your Python will complete the most complex multi-tool tasks efficiently.

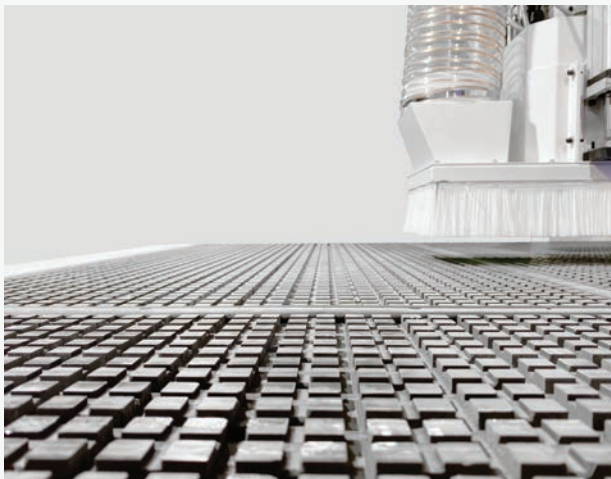

ROBOTIC MATERIAL SENSING

This patent-pending game changer keeps your shop clean and employees safe. The Python automatically detects the thickness of the material and the corresponding height of its required tool. This “sensing” allows the dust hood to hover at the perfect spot over your material, creating a seal to prevent dust from escaping without bending the dust brush, whether you are switching from thin to thick materials, or are using short or longer tools.

5G CNC FEATURES



5TH GENERATION HELICAL RACK & PINION

5G helical rack and pinion powers the Python XPR with absolute positioning at all times. Even with no power, the Python knows its position at all times. The new CNC Driverless technology takes away frustrating machine homing and multiple alignment switches. Integrated anti-backlash 5G servo & uniform load distribution produce constant gear contact among several axes— increasing, speed, life and accuracy.



12HP HSD AIR-COOLED ATC SPINDLE

The Python XPR is built with a 12HP HSD air-cooled ATC spindle (1,000-24,000 RPM) and performs with precision and speed. Compared to traditional circular units, our Italian-made HSD spindle is pneumatically driven with oval section pistons to guarantee a 35% increase in thrust and increase in production by up to 30%. Installed Delta inverter ensures variable speeds and on-board protection. The spindle is a key component of the Python machine center and is protected by the CNC Factory advance exchange program, ensuring constant operation and lifetime support.



PRESSURIZED OIL LUBRICATION

It's integrated with a lubrication system to deliver oil to critical lubrication points automatically... so there's no forgetting to lubricate all areas; minimizing the risk of damage to your equipment and performance.

Unlike other brands who use *centralized* lubrication, the Python's is **pressurized**, so you only get lubrication to areas that need it— avoiding overlubrication which can cause oil leaks to your materials.



DUAL-LAYER, HIGH-FLOW VACUUM FOR AGGRESSIVE MATERIAL HOLD DOWN

Driverless vacuum technology makes the need for a seasoned operator a thing of the past with constant vacuum hold-down communication with the Python. It includes the advanced, dual-layer, phenolic vacuum grid table with over 80 vacuum access points, giving you an increased hold down over standard single layer systems. The Python can alert the operator if vacuum hold down falls to an unsafe level before running a program. The Python is pre-configured for single or dual vacuums.

5 G CNC FEATURES



EASY MARKING

Never lose cut parts again. The Python can be upgraded with a Deluche Vision Marking Tool that marks post-production instructions, such as edge banding, directly on cut components. This marking tool fits directly into your tool holder and is ready to use with current cabinet-cutting software. Human mistakes are eliminated because the directions are right on the cut components. No more production stopping or hard-to-read prints to mark edges. Use one marking tool for each set of instructions you want printed on cut boards. Marks easily wipe away with an alcohol swab with no leftover residue.

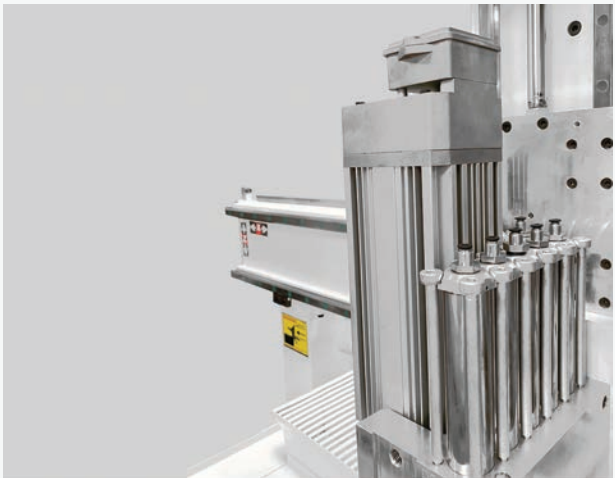

DRILL BLOCK READY

Optional 9-head HSD drill block produces 5 drills in both directions—boosting production speeds for drilling and boring operations. The optional drill block can be installed anytime but already has pre-installed, drill block mounting, power and data.



ROBOTIC PRINTING & APPLICATION

Manually identifying or applying pre-printed labels on cut parts is a time waste and prone to errors. The Python's on-board label printer prints text & image labels which are precisely applied by a robotic arm. No double-checking needed.

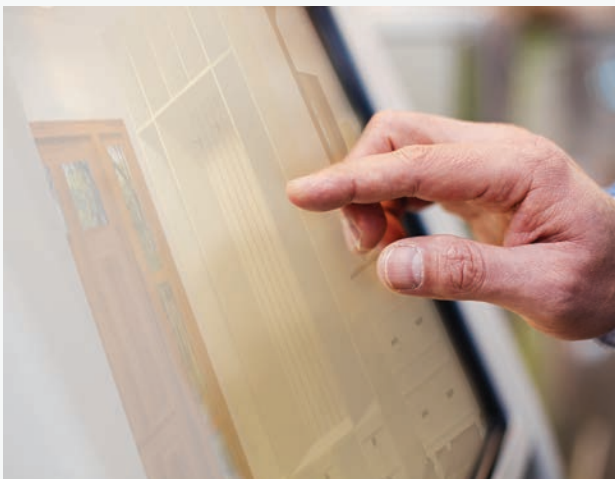

NO EXPERIENCE NECESSARY

Its new user-friendly interface comes with a CNC cabinet software that helps beginners generate shop drawings, 3D customer renderings, cutting lists, material requirements, estimates, CNC machining and so much more.

- Touch screen interface
- WiFi connectivity
- Camera for remote access & diagnostics
- With built-in V-Carve

5G CNC FEATURES

NO MACHINE HOMING OR ALIGNMENT

Machine homing and aligning is a thing of the past with the Python. With driverless technology and 5th generation CNC control, your Python will know its location at all times. Simply turn on and you're ready for operation. There's no need for time-wasting homing every time your machine loses power or is reset.

HANDS-FREE & CONTINUOUS LOADING

Robotic material loading and unloading arms save you from back-breaking lifting. Pneumatic pop-up pins assist in manual and automatic material placement. The dual-layer, high-flow vacuum table removes any leftover debris so there's no downtime between reloading sheets.



WIRELESS HANDHELD REMOTE WITH CNC SIMULATION

The driverless remote and MPG Controller allows for effective at-machine management including manual control of all axes with selectable speed controls. The MPG simulation wheel allows to scroll through a live program, forward and backwards, to ensure accuracy and CNC performance.

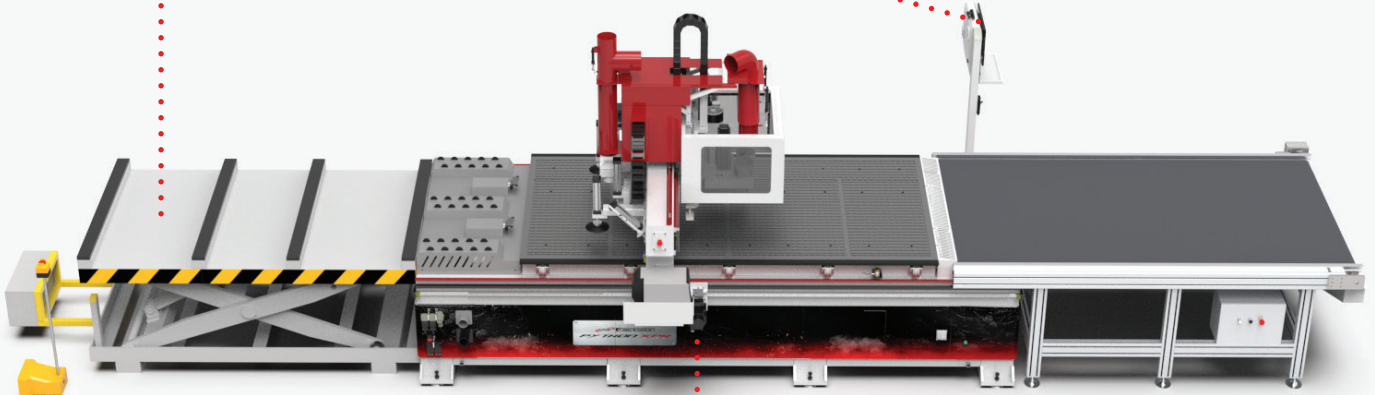

ONBOARD AIR CONDITIONING/COOLING

Heat extraction with digitally-set air movement installed directly inside the Python onboard control center provides a constant, high air flow and pressure. This helps stabilize the control cabinet operations in the most demanding environments and protects critical components over years of operation.



TECHNICAL SPECS

Speeds	1000 inches per minute cutting, 2500 inches per minute rapid movements
Spindle	12HP HSD (9kw) ISO-30 air cooled ATC spindle with manual release
Carousel ATC	<ul style="list-style-type: none"> • 12-position ISO-30 servo controlled rotary carousel ride-along ATC tool changer (8 seconds) • Twelve (12) ISO ER-30 tool holders and ER wrench included • Auto tool length measurement sensor included
CNC Controller	<ul style="list-style-type: none"> • 5th generation 21" touch screen industrial control center with handheld controller and easy button operation • Built-in continuous operation file saving and production override with speed control • G-Code compatible with virtually every CAD and woodworking software. • Tool wear history with built-in alarm stops, USB, WiFi, ethernet, work coordinates and on-screen programming
Cooling	On-board integrated air conditioner
Network Communications	Windows 10 front end with ethernet ready connection and WiFi compatible
Software Installed	KCD Software option. The Python is compatible with virtually all G-code
Servo System	Yaskawa 5G encoding system with self-adjusting servo operations
Repositioning	Acceleration and deceleration working and repositioning within +/- .001"
CNC Voltage & Air	208-240 Volts, 3-Phase, 30amp. 120psi, 8 bar, 9 cfm.
Dust Collection	Minimum of 2800 CFM. Single 6" dust port on top of machine

PLUG & PLAY GROWTH

The Python XPR is already a complete CNC solution for the woodworker. It has all the features of our Viper XP, Sidewinder XPR, and more.

If your shop grows and needs additional upgrades, the Python can still accommodate them with its plug & play capability. That's 5th generation CNC Power.

Upgrade at anytime; the Python XPR is ready when you are!

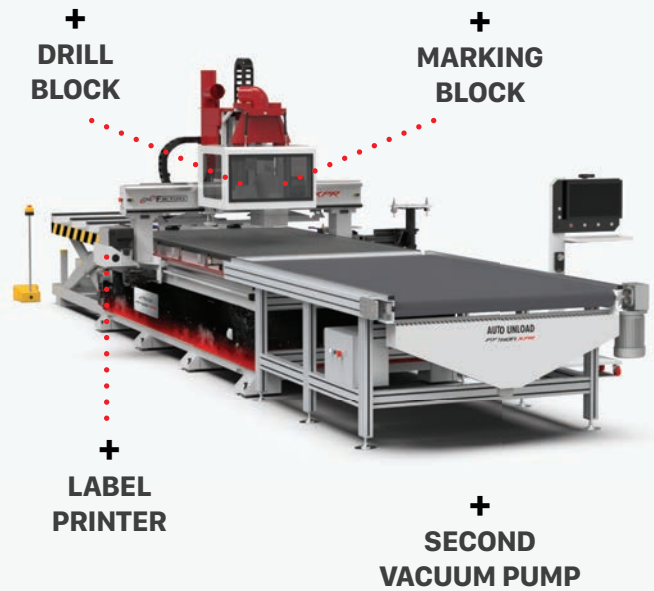

PRICING PER PROCESS AREA

Every Python XPR order comes with CNC University Certification & Lifetime Support.

\$76,800	Python XPR 4' x 8'
\$78,600	Python XPR 4' x 10'
\$80,600	Python XPR 5' x 10'
\$82,600	Python XPR 5' x 12'
+ \$1,800	Single phase conversion

ANYTIME UPGRADES

\$6,900	HSD 9-Position drill block
\$3,200	4-Port Robotic Marking Block
\$6,900	V300 Rotary Vane Vacuum Pump (2 pumps allowed for the Python)
\$8,900	Zebra Robotic Printing & Applicator

TRAINING OPTIONS

Free	CNC University Training
\$3,500	Additional 2-day onsite installation & training

FOOTPRINT

Processing Area	Table Size	4' x 8'	4' x 10'	5' x 10'	5' x 12'
X-Axis Width		49"	49"	61"	61"
Y-Axis Length		97"	121"	121"	145"
Z-Axis Height		11.5"	11.5"	11.5"	11.5"
Z-Axis Clearance		Up to 4.5" clearance with unloading arm		Custom size tables and configurations available	
		Up to 7" clearance without unloading arm			

Footprint

4' x 8' Table
99.5" x 152" x 101"H
7200lbs.

5' x 10' Table
111.5" x 176" x 101"H
7800lbs.

4' x 10' Table
99.5" x 176" x 101"H
7600lbs.

5' x 12' Table
111.5" x 199" x 101"H
8500lbs.

4' X 8', 5' X 10' AND 5' X 12' TOP VIEW

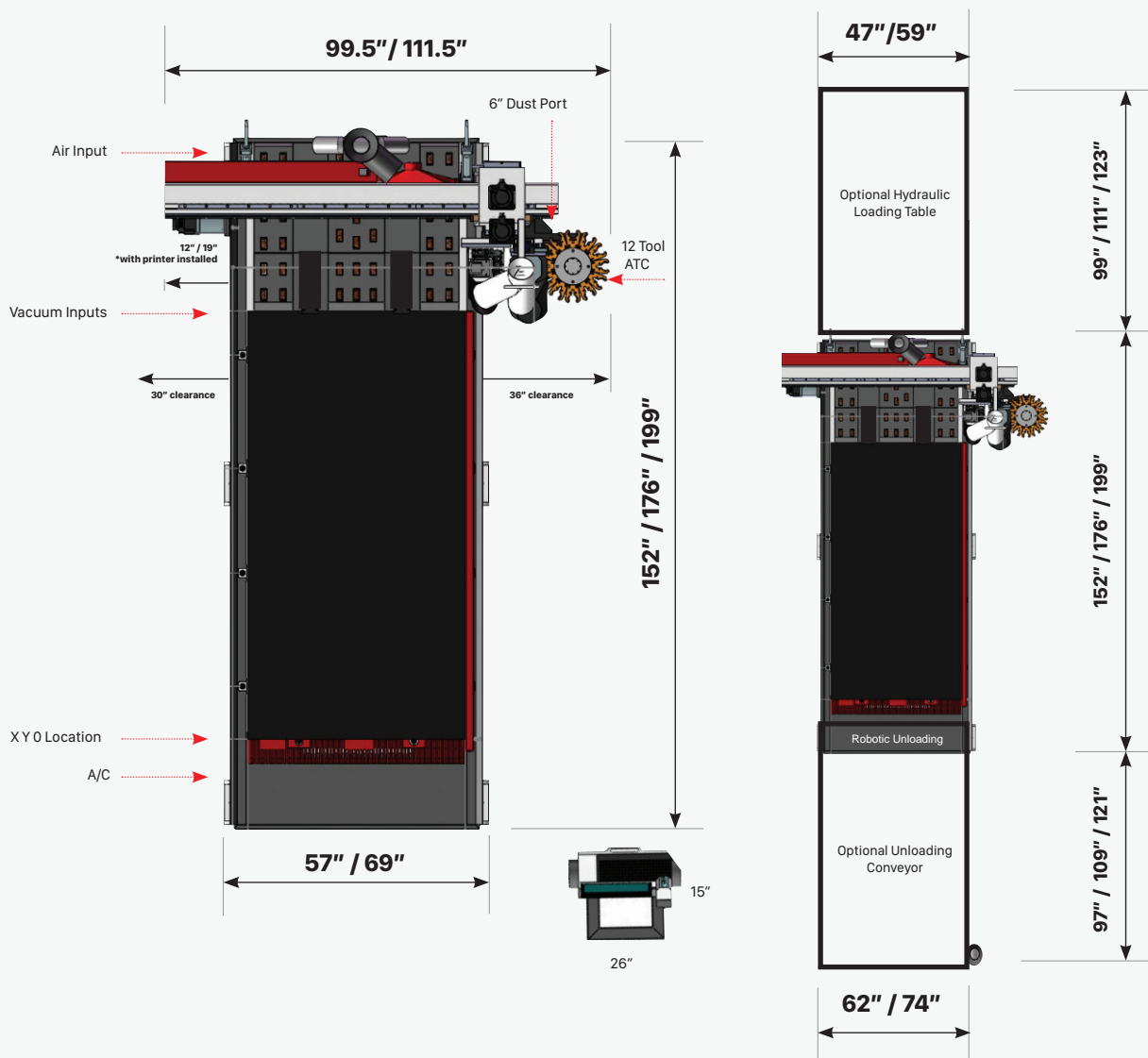

INSTALLATION NOTES

AC - CNC Machine:	208/220/240 Volt, 3-Phase, 60 hertz. 30amp
AC - Vacuum Pump:	208/220/240 Volt, 3-Phase, 60 hertz. 50amp
Air Pressure:	(3/8" inlet) 8 bar (120psi) 9 CFM
Dust Collection:	Min. of 2800 CFM. Single 6" dust port on top of machine 97" height

PYTHON DRIVERLESS CONTROL & SOFTWARE



Digital camera for remote access and diagnostics

Large 21" touch LCD screen with Play/Pause button operations & remote vacuum start

Our Driverless controller has one of the smallest footprint in the industry.

The model here stands at 5'6".

- Driverless with virtual, WiFi and at-the-machine operations
- Wireless CNC hand-held controller
- On-board CNC air conditioning
- Pick and choose cabinets and cutting from pre-installed software or install your own as your needs grow
- Python is virtually compatible with all cabinet and CAD/CAM software
- Vacuum hold-down communication and material unloading at a touch of a button
- Material alignment pins, automatic vacuum flow with integrated sensor communication
- Robotic unloading, including pressurized dust hood and spoilboard cleaning
- Tool measuring, spoilboard surfacing, spindle warmup, MPG controller and feed rate overrides

PYTHON DRIVERLESS SOFTWARE OPTION



V-Carve Professional provides a powerful but intuitive software solution for creating and cutting parts on a CNC Router. V-Carve Pro gives you the power to produce complex 2D patterns with profile, pocket, drill and inlay toolpaths - plus gives you the ability to create designs with V-carving textures as well as import and machine unlimited Vectric 3D clipart or single model files. The 'Pro' edition gives you unlimited jobs and toolpath size, true shape nesting & job set-up sheets, ideally suited to a production environment.



PYTHON DRIVERLESS CONTROL & SOFTWARE

KCD software

KCD Cabinet and Closet Software is integrated* into the new Python XPR driverless technology with a machine library and operations, including design for manufacturing software tools, for residential and commercial casework. KCD Software takes you from Design to CNC machining, and will generate detailed, dimensional drawings, elevations, floor plans, 3D renderings, material requirements, cut lists, and estimates and proposals. KCD Software is recognized as the leading software for ease of use, growth and support.

- **Pricing and Bidding**

Generate instant estimates, proposals and contracts for accuracy in job bidding and closing sales.

- **Detailed Dimensional Drawings to Scale**

Easily combine, organize and display your professional drawings to your contractors and shop.

- **Quality Renderings**

Impress your next potential client with your presentations and win more projects.

- **Accurate Cut Lists**

Reduce production time and eliminate waste when your cut lists are right the first time.

- **Online Knowledge Center**

Free access to KCD Software's extensive training video library, documentation and much more.

- **Software with Free Live Support**

Get the phone support you need with extraordinary customer service.



The power of the machine center gives you direct machine capabilities right from your mobile control center. Paired with KCD Software, this is an easy way to communicate with your Python XPR. Whether making a single cut or multi-sheet project from KCD Software, your Python XPR center can automatically process your parts, eliminating the extra costs of a dedicated programmer.

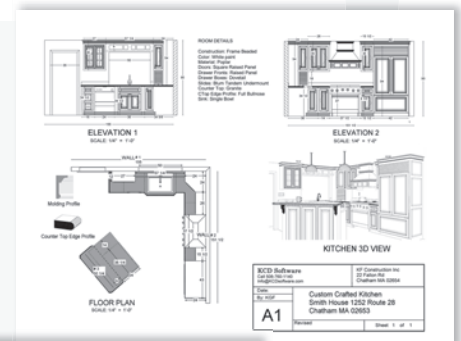

- KCD tailored for the Python XPR
- Basic Individual DXF Import
- Integrated Label Reports
- Integrated Reporting
- Check Sheet Sizes to Fit Machine
- Pattern Diagram Print Outs
- Automatic Tooling and Tool Path Generation
- Pocketing of Rectangles and Circles
- Basic Toolpath Simulation
- Ability to Control Lead-In/Out Offsets
- Linked Part Outline (Bridge) Nesting
- Intelligent Small Part Handling (Tabs, Onionskins, Return Onionskins)
- Combine Operations on Part Edge with Part Outline



*Must be pre-qualified for the KCD Software 6-month CNC Commander trial. Contact KCD Software for details. 508-760-1140 or sales@KCDSoftware.com

TERMS AND INSTALLATION

Terms of Payment

Terms of payment offered, or any terms agreed upon, are subject to credit approval if needed. This offer is subject to CNC Factory General Terms and Conditions of Sale. Price quoted is for the machine as described above and is subject to change with notice or if the specifications for the machine are changed at the request of the buyer.

Shipment

Shipment is subject to delay should changes be made to meet the requirements of the purchaser from CNC Factory's design specification stated herein. Exact shipping costs are included in your official quote from a CNC Factory sales rep.

Tooling

- Tooling is not included. Upon request, we can supply a quotation on the most suitable tools required for use on this machine.
- Twelve (12) ISO-30 tool holders and ER wrench are included in this order.

Installation, Training, Support and Conditions

Installation, when purchased, will be performed by a CNC Factory-trained service technician or Certified Dealer Technician. Installation is to be understood as the assembly of the machine to the "ready to run" state. It does not include floor, masonry work, machine leveling, the running of electrical, pneumatic or dust extraction services to the site. Training will be on the machine operations only. Software training, if any, can be done before or after installation by CNC Factory University training services. Training will be conducted on site by the service technician after installation has been completed.

CNC Factory is committed to maximizing your production time. Your machine may contain built-in safety/operational messages. You can contact CNC Factory Support Department at 714-581-5999 if you receive a machine message.

Warranty and Lifetime Support

CNC Factory is proud to give you a lifetime of machine support and warrants the machinery will be free of defects in workmanship and materials for a period of 18 months beginning on the date of delivery. This warranty does not include parts consumed during normal operation (wearable) or maintenance required in the ordinary course of operation.



CNC FACTORY 5G CNC ROUTERS

	<i>VIPER</i>	<i>SIDEWINDER</i>	<i>PYTHON</i>
5th Generation CNC Features			
ATC Air-Cooled Spindle	10HP	12HP	12HP
No Homing or Alignment Servo System	✓	✓	✓
Axis Motor Size (X&Y)	Servo 750W	Servo 750W	Servo 850W
Axis Motor Size (Z)	Servo 1300W	Servo 1300W	Servo 1300W
Driverless Mobile Touch Screen & Remote Controller	✓	✓	✓
Cutting Speed	800 IPM	900 IPM	1000 IPM
Travel Speed	1800 IPM	1800 IPM	2500 IPM
Auto Tool Measuring	✓	✓	✓
ATC Tool Changer Setup	on gantry bar	rotary carousel	rotary carousel
ATC Tool Changer Capacity	8 tools, upgradable to 12	8 tools, upgradable to 12	12 tools
Tool Change Time	8 seconds	8 seconds	8 seconds
5G Helical Rack & Pinion (X & Y axes)	✓	✓	✓
Network, WiFi, USB Connectivity	✓	✓	✓
Onboard Air-conditioning & Cooling	✓	✓	✓
Pressurized Automatic Oil Lubrication	✓	✓	✓
5G Servo System	✓	✓	✓
Compatiblilty with popular CAD/CAM software	✓	✓	✓
Servo Gear Reduction	✓	✓	✓
Intelligent Zoned High-flow Vacuum System	single layer	dual layer	dual layer
Material Position Pins & Guide Rails	✓	✓	✓
Robotic Material Alignment	X	upgradable	✓
Robotic Cleaning & Unloading	X	✓	✓
Robotic Material Sensing for Dust Extraction	X	upgradable	✓
Deluche Vision Marking Tool	sold separately	sold separately	sold separately
V300 Intelligent Vacuum Pump	sold separately	sold separately	sold separately
Robotic Label Printing & Application	X	X	upgradable
Built-in Software & Tool Holders			
KCD (if pre-qualified for KCD 6-month CNC Commander Trial)	✓	✓	✓
VCarve Pro	✓	✓	✓
ISO-30 Tool Holder	8 Tools	8 Tools	12 Tools
Production Upgrades			
Custom-sized tables	✓	✓	✓
Custom gantry height	✓	✓	✓
Single-phase power conversion	✓	✓	✓
Anytime Upgrades			
Spindle	to 12HP	X	X
9-Position Drill Block	✓	✓	✓
ATC tool	up to 12	up to 12	X
4- Port Marking block	✓	✓	✓
V300 Vacuum Pump	✓	✓	✓
Deluche vision marking tool	✓	✓	✓
Mister	✓	✓	✓
Robotic Material Alignment	X	✓	included
Robotic Loading Arm	X	✓	included
Hydraulic Automated Loading Table	X	✓	included
Unloading Conveyor with Material Sensing	X	✓	included
Robotic Label Printing & Application	X	X	✓
Training			
Lifetime Technical Support	✓	✓	✓
CNC University Certification	✓	✓	✓
On-Site Support	sold separately	sold separately	1 year
Warranty			
Advance Exchange Program on Major Components	5 years	5 years	5 years
Warranty	18 months	18 months	18 months